

lyricstraining

Learn languages online
with music videos and lyrics.

lyricstraining

Learn languages online
with music videos and lyrics.

LEARNING

lyricstraining

Learn languages online
with music videos and lyrics.

WITH

lyricstraining

Learn languages online
with music videos and lyrics.

MUSIC

lyricstraining

Learn languages online
with music videos and lyrics.

lyricstraining

Learn languages online
with music videos and lyrics.

In this presentation we will

- Think about the generation of students we have.
- Briefly talk about the benefits of listening music.
- Think on how to engage students to learn another language, with the music that they love.
- Learn how to use the web site lyricstraining.com.

By the end of this presentation you will

- Set up a free lyrics training account.
- Have practiced singing a song in a language you are not familiar language.
- AND you will have a fun, ready to use closing session tool, with students ready to use in a class

Generation, generation, and... (Guess What???) a generation GAP!!

- Talk to your neighbor and ask them what is the name of their generation?
- How many of us know the “name” of our own generation?
- It is the generation we were born into important when we discuss teaching and learning?

***WHAT GENERATION ARE WE
TEACHING?***

MILLENNIALS

- We teach them
- Born into technology
- QUESTION:

When not on social media, what are they doing???

YOU ARE RIGHT!
They love to listen music



WHAT'S HAPPENING IN YOUR BODY WHEN YOU LISTEN TO

MUSIC

Memory

You form and recall memories due to the release of dopamine.

Mood

Your mood is boosted due to the release of the "feel-good" neurochemical dopamine.

Work Performance

You perform better on spatial tasks and standardized tests.

Blood Pressure

Your blood pressure falls (or rises) depending on the speed and type of music you listen to.



The moment you press "play," a number of things happen in your brain and body.

Exercise Ability

You're able to push harder and longer in your workout due to music's effect on your physical capacity and arousal.

Skin

You actually experience physical sensations on your skin in response to particularly moving music.



WHAT IS *lyricstraining* ?

Learn languages online
with music videos and lyrics.

According to the website:

LyricsTraining is an easy and fun way to learn and improve your foreign languages skills, through the music videos, and the lyrics of your favorite songs. LyricsTraining also has a special Karaoke mode that lets you sing and enjoy the full lyrics.

It is essentially an online cloze activity that uses the music video in the background. It is a valuable tool for teaching a foreign language as you can select level of difficulty

LyricsTraining and Language Learning

- LyricsTraining helps you to learn new vocabulary and expressions as well as reinforce grammar concepts through continuous exercise of writing the missing words.
- Above all, LyricsTraining helps you train your ear to dramatically improve your capacity to recognize sounds and foreign language in a very short time and train your brain almost unconsciously whether you know the meaning of all the words or not.

- LyricsTraining.com studies have shown that simple exposure to the sounds of another language sets up in the brain structures and connections necessary for learning.
- In addition, music is a fun way to learn and listening to different accents and pronunciations allows greater flexibility to test to your ability to recognize the different sound patterns of another language. This is very different from typical language classes are more formal than practical; which is not day to day practical use.
- LyricsTraining is also a fun way to learn your favorite songs.



Improve your listening comprehension and practice with different accents interacting with the best musical videos, filling the gaps in the lyrics and using the Karaoke



Top Lyrics (Today)



1  #ENG 

vevo 06:07

Hello
Adele



10 months | 2428 plays
[Gabrielle_](#)

2  #ENG 

vevo 05:02

Sugar
Maroon 5

1 year | 1715 plays
[j.crissnell](#)

3  #ENG 

vevo 03:46

Let It Go
Idina Menzel

2 years | 1440 plays
[Homer8956](#)

Many languages to choose from and more are coming soon....

The image shows a screenshot of the lyricstraining website. At the top left is the logo "lyricstraining" in blue. To its right are "Genres" with a dropdown arrow and a search bar with a magnifying glass icon and the word "Search". On the far right is a "Language" dropdown menu with a downward arrow. Below the logo is a dark blue navigation bar with the text "READY TO USE GRAPHIC ASSETS" in light blue. Underneath this bar are several dark buttons with white text: "FREE ITEMS", "TEMPLATES", "MOCKUPS", "ICONS", "VECTORS", and "TEXTURES". Below the navigation bar is a large video player showing a man's face in a close-up, with a play button in the center and a "YouTube" logo in the bottom right corner. To the right of the video player is a vertical list of language options, each with a flag icon and the language name: "All Languages" (highlighted), "English" (with the UK flag), "Spanish" (with the Spanish flag), "Portuguese" (with the Portuguese flag), "French" (with the French flag), "Italian" (with the Italian flag), "German" (with the German flag), "Dutch" (with the Dutch flag), and "Japanese (Romaji)" (with the Japanese flag). The bottom of the page shows a partial view of a "3 d" and "Ma" link.

It even has 4 game modes to choose from
AND more are to come!!

Select a Game Mode

Beginner

Fill 18 random words of 184 (10%)

Intermediate

Fill 46 random words of 184 (25%)

Advanced

Fill 92 random words of 184 (50%)

Expert

Fill all the words (184), are you crazy?

Even with network restrictions, you can print it!

- Print full lyrics.
- Manual selection of the blanks.
9 blanks selected.

Click on the words to put and remove blanks.

Options:

- Show line index.
- Show missing words.
- Show line at the top to enter the name and date.

Print Now

Heartless Kanye West

In the _____, I hear 'em talk
The coldest _____ ever told
Somewhere far _____ this road
He lost his _____ to a woman so heartless
...
How could you be so _____?
...
How _____ you be so heartless?
How could _____ be so, cold as the winter wind when it breeze, yo
Just remember that _____ talkin' to me though
You know need _____ watch the way you talkin' to me, yo

And if you can't find the song you want, you can upload your own favorite songs and edit the written lyrics!

How To Play

Write the song lyrics while listening the music:

- » To continue playing you must complete each line.
- » To listen again the last line, press backspace key.
- » If you can't understand a word, press tab key to jump to the next.
- » Don't write spaces neither any special character.

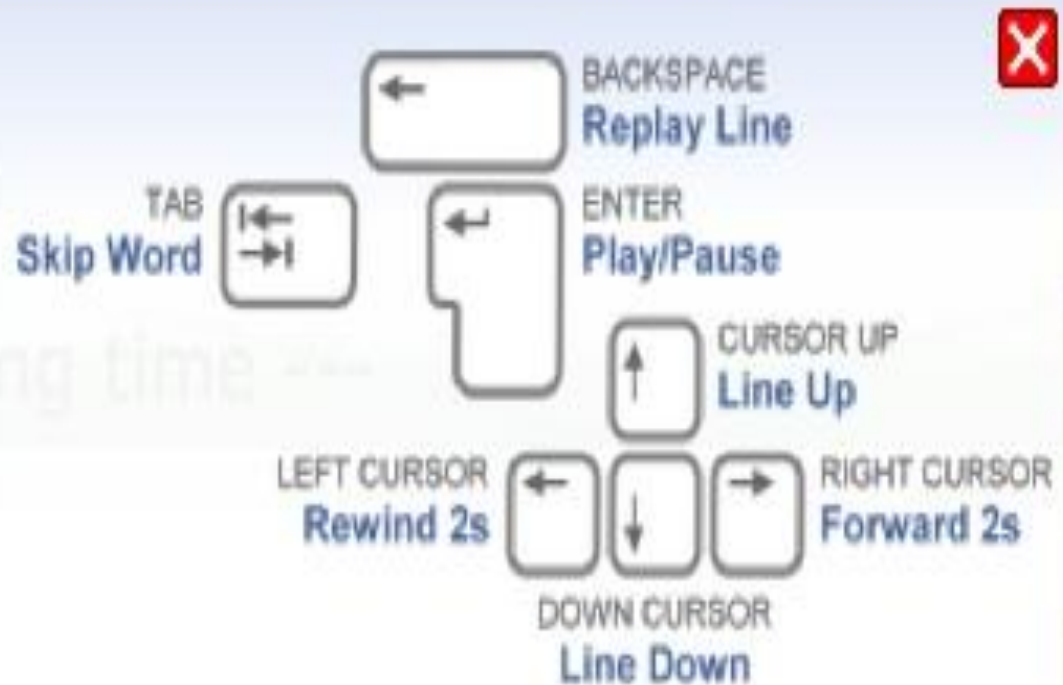

WARNING

Like anything from the web lyricstraining can be a good thing or a bad thing.

Make sure to do your due diligence before students surf the link as any user is allow to add lyrics and files as they see fit.

Has pop up adds

Some ideas on how to use Lyricstraining

- As a cloze activity in class (as a whole class or one on one)
- If you can not access youtube with your DOE computer, an option is to use another computer to download a copy of the file onto a CD to share with your students.
- As ‘homework’ for practicing listening comprehension, assign a song.
- Students can compete

Closing Comments

maesramayra2@gmail.com

"WAIPAHU HIGH SCHOOL"

Edna Mayra Hickling